

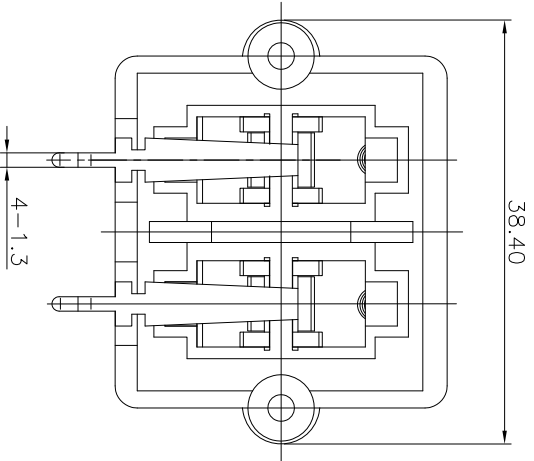

REV.	ECN NO.	MODIFIED MARK	APPROVED
A		FIRST RELEASE	

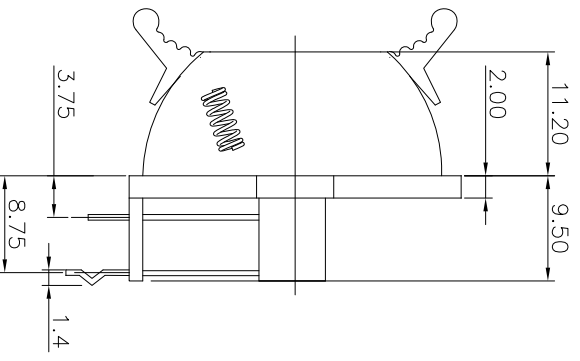

NOTES:
ELECTRICAL:
1:RATED CURRENT: 3A Max.
2:RATED VOLTAGE: 50V AC.
3:INSULATION RESISTANCE: 100 MEGAOHMS Min.
4:DIELECTRIC WITHSTANDING VOLTAGE: 1200 VAC Min.
MECHANICAL:
1:WIRE IN HOLD FORCE 5N (20#WIRE) MIN
2:INSPECTED VOLTAGE, AT THE SPEED OF 6-10S PER MINUTES, THE SAMPLES ARE INSPECTED 10000 CYCLES, BUT THERE ARE NO DAMAGE ON THE PRESSURE AND THE RISING TEMPERATURE, ETC.3:APPLY 2kgf FORCE AT ANY DIRECTION , THERE NO LOOSE & NO CRACK

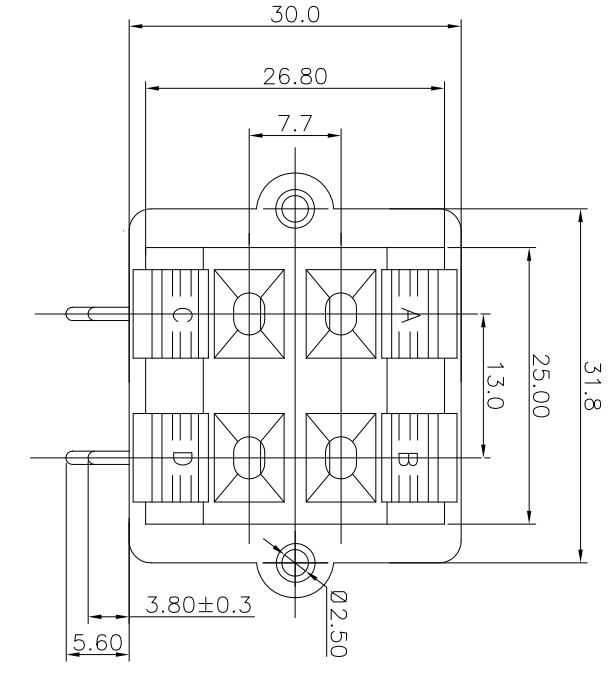
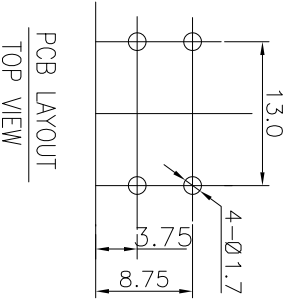
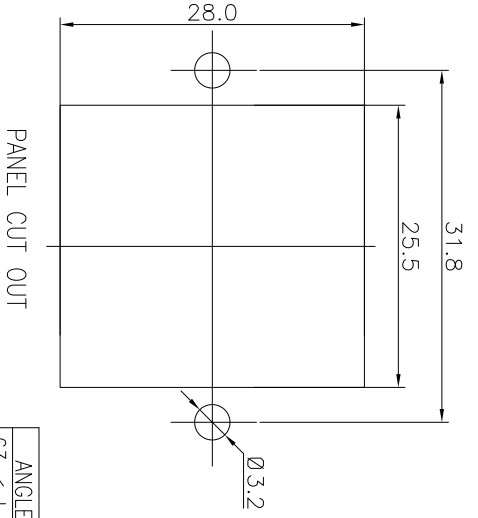

ANGLE	±5°	MODEL NAME: WP4-3 (PART NO.)	 广东正宝科技有限公司 GUANGDONG TRENPRO TECHNOLOGY CO., LTD.	TITLE: WP PUSH TERMINAL	REV.: A
63 < L	±0.5	MAT'L: See table		DWG NO.:	UNIT: mm
16 < L ≤ 63	±0.4	FINISH: See table	CHECKED: L.W.Wu 11/06'18	SCALE: 5:1	SHEET: 1/1
4 < L ≤ 16	±0.3	Q'TY: /	DESIGN: X.H.Wang 11/06'18	APPROVED: X.Q.Hu 11/06'18	SIZE: A3
L ≤ 4	±0.2	TOL TABLE:			
THIS DOCUMENT IS THE PROPERTY OF TRENPRO TECHNOLOGY CO., LTD. NO PART THEREOF MAY BE REPRODUCED AND USED WITHOUT THE PRIOR WRITTEN CONSENT OF THE OWNER					