

REV.	ECN NO.	MODIFIED MARK	APPROVED
A		FIRST RELEASE	

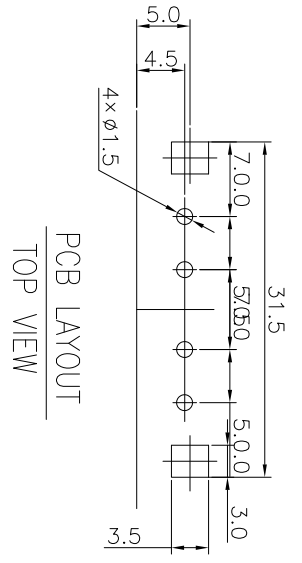

PCB LAYOUT
TOP VIEW

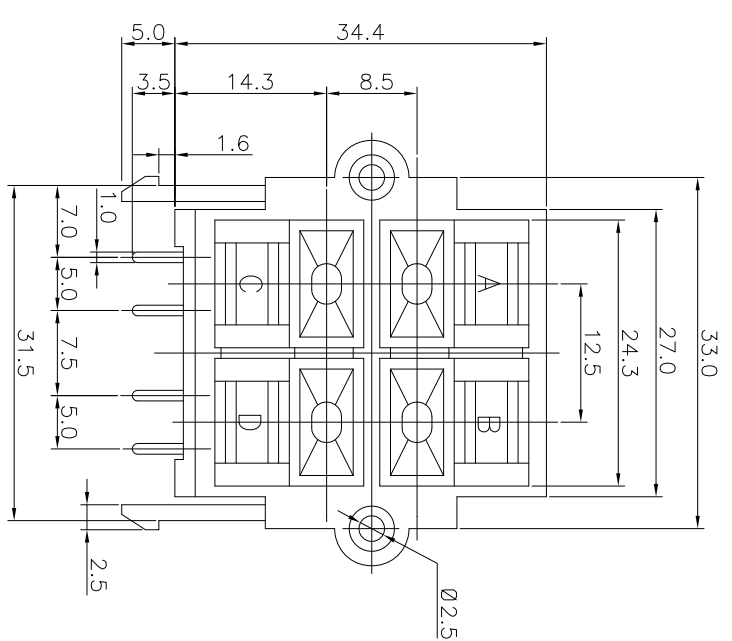
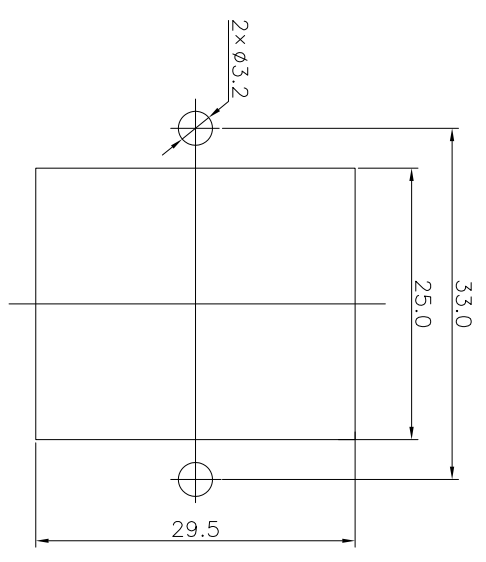
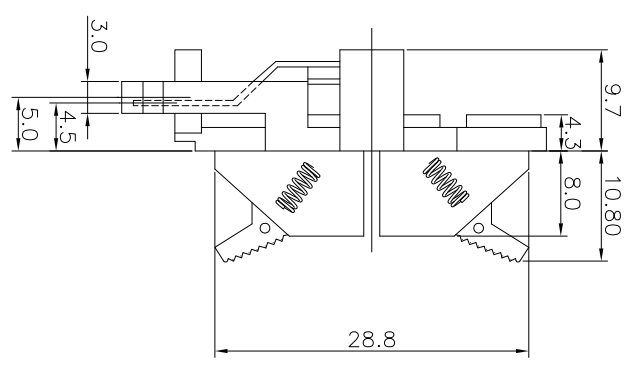

PANEL CUT OUT

NOTES:
ELECTRICAL:
1:RATED CURRENT: 3A Max.
2:RATED VOLTAGE: 50V AC.
3:INSULATION RESISTANCE: 100 MEGAOHMS Min.
4:DELECTRIC WITHSTANDING VOLTAGE: 1200 VAC Min.
MECHANICAL:
1:WIRE IN HOLD FORCE 5N (20#WIRE) MIN
2:INSPECTED VOLTAGE, AT THE SPEED OF 6-10S PER MINUTES, THE SAMPLES ARE INSPECTED 10000 CYCLES, BUT THERE ARE NO DAMAGE ON THE PRESSURE AND THE RISING TEMPERATURE, ETC.3:APPLY 2kgf FORCE AT ANY DIRECTION , THERE NO LOOSE & NO CRACK

ANGLE	±5°	MODEL NAME: WP4-14	 广东正宝科技有限公司 GUANGDONG TRENPPO TECHNOLOGY CO. LTD.
63 < L	±0.5	(PART NO.)	
16 < L ≤ 63	±0.4	DESIGN: X.H.Wang 11/06'18	TITLE: WP PUSH TERMINAL
4 < L ≤ 16	±0.3	CHECKED: L.W.Wu 11/06'18	DWG NO.:
L ≤ 4	±0.2	MAT'L: See table	REV.: A
TOL TABLE:		FINISH: See table	Q'TY: /
THIS DOCUMENT IS THE PROPERTY OF TRENPPO TECHNOLOGY CO., LTD. NO PART THEREOF MAY BE REPRODUCED AND USED WITHOUT THE PRIOR WRITTEN CONSENT OF THE OWNER		APPROVED: X.Q.Hu 11/06'18	UNIT: mm
		SCALE: 5:1	SHEET: 1/1
		SIZE: A3	