

REV. A	ECN NO.	MODIFIED MARK	APPROVED
		FIRST RELEASE	

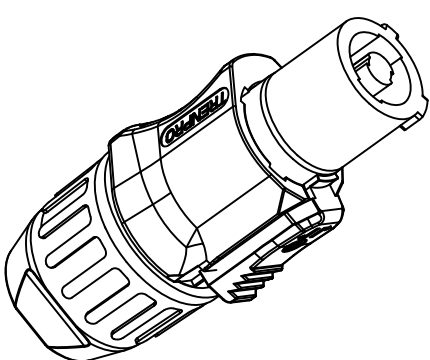
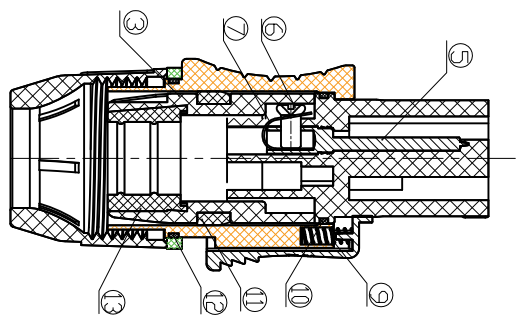
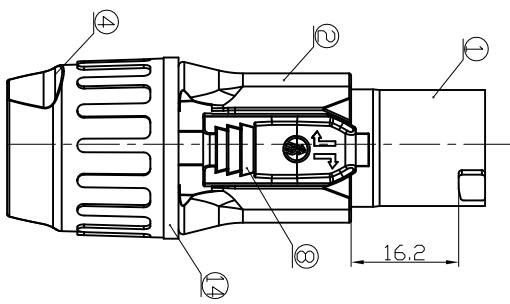
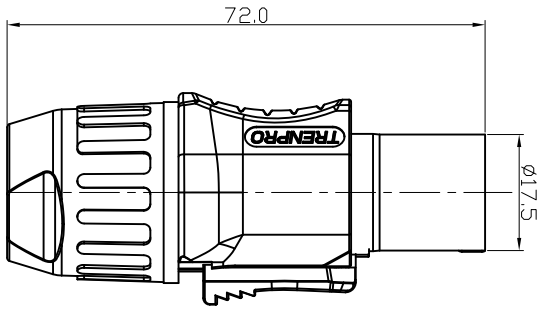
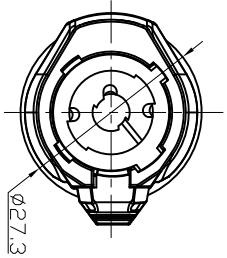

NOTES:
ELECTRICAL:
1:RATED CURRENT: XLR: 20 A MAX JACK: 15 A MAX
2:RATED VOLTAGE: XLR: 250 V AC JACK: 250 V AC
3:CONTACT RESISTANCE: 30 MILLIOHMS MAX.
4:INSULATION RESISTANCE: 1 G OHMS MIN.
5:DIELECTRIC WITHSTANDING VOLTAGE: 1000 VAC MIN.
MECHANICAL:
6:DURABILITY: 1000 CYCLES.
7:WATERPROOF GRADE:IP65

COLOR TABLE

P/N	COLOR
1	BLACK
2	BLUE
3	YELLOW
4	RED
5	GREEN
6	WHITE
7	CYAN

NO.	PART NAME	Q'TY	MATERIAL	FINISH/COLOR	REMARK
14	RING	1	PA66	SEE COLOR TABLE	RoHS
13	WASHER-D	1	RUBBER	BLACK	
12	WASHER-C	1	RUBBER	BLACK	
11	WASHER-B	1	RUBBER	BLACK	
10	WASHER-A	1	RUBBER	BLACK	
9	SPRING	1	STEEL $\phi 0.3$	BLACK	
8	PUSH	1	ZINC	NI PLATED	
7	TERMINAL	3	BRONZE $t=0.25$	NI PLATED	
6	NUT	3	STEEL	NI PLATED	
5	PIN	3	BRASS	Ag PLATED	
4	BACK COVER	1	PA66	SEE COLOR TABLE	
3	CRAMP	1	PA66	BLACK	
2	COVER	1	PA66	SEE COLOR TABLE	
1	HOUSE	1	PA66	SEE COLOR TABLE	

NO.	PART NAME	Q'TY	MATERIAL	FINISH/COLOR	REMARK
ANG	ANGLE	$\pm 5^\circ$			
16 < L		± 0.5			
16 < L < 63		± 0.4			
4 < L < 16		± 0.3			
L < 4		± 0.2			

TOL TABLE:	See table
FINISH:	CHECKED:
Q'TY: /	APPROVED:
DESIGN:	
TITLE:	PLE PLUG
DWG NO.:	
UNIT:	mm
VIEW:	
SCALE:	5:1
SHEET:	1/1
SIZE:	A3
REV.:	A

MODEL NAME: PLE3-01FB
(PART NO.)

THIS DOCUMENT IS THE PROPERTY OF
TRENPRO TECHNOLOGY CO. LTD.
NO PART THEREOF MAY BE REPRODUCED
AND USED WITHOUT THE PRIOR WRITTEN
CONSENT OF THE OWNER



广东正宏科技有限公司
GUANGDONG TRENPRO TECHNOLOGY CO. LTD.