

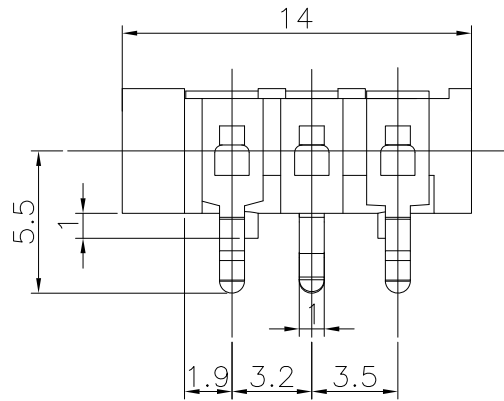

REV.	ECN NO.	MODIFIED MARK	APPROVED
A	—	FIRST RELEASE	

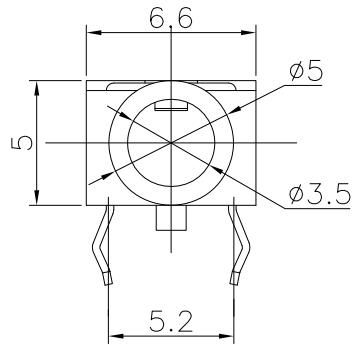

NOTES:  
 ELECTRICAL:  
 1:RATED CURRENT: 1A Max.  
 2:RATED VOLTAGE: 30V AC.  
 3:CONTACT RESISTANCE: 100 MILLIOHMS Max.  
 AFTER TESTING:100 MILLIOHMS Max.  
 4:INSULATION RESISTANCE: 100 MEGAOHMS Min.  
 5:DIELECTRIC WITHSTANDING VOLTAGE: 500 VAC Min.  
 MECHANICAL:  
 1:INSERTION FORCE: 3N-25N.  
 2:WITHDRAWAL FORCE: 3N-25N.  
 3:DURRABILITY: 5000 CYCLES.  
 ENVIRONMENTAL:  
 TEMPERATURE RANGE: -20°C TO 60°C.

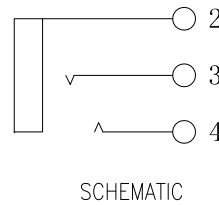
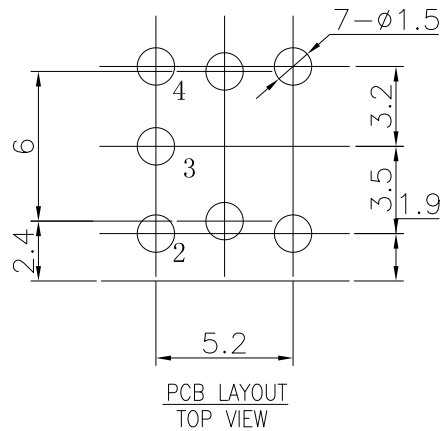

ANGLE	±5°	MODEL NAME: SJ3506A (PART NO.)		 广东正宝科技有限公司 GUANGDONG TRENPRO TECHNOLOGY CO. LTD.				
63 < L	±0.5	MAT'L: See table	DESIGN: X.H.Wang 11/05'18	TITLE: 3.5 PHONE JACK				
16 < L ≤ 63	±0.4			FINISH: See table	CHECKED: L.W.Wu 11/05'18	DWG NO.:	REV.: A	
4 < L ≤ 16	±0.3	Q'TY: /	APPROVED: X.Q.Hu 11/05'18					UNIT: mm
L ≤ 4	±0.2			THIS DOCUMENT IS THE PROPERTY OF TRENPRO TECHNOLOGY CO. LTD.,NO PART THEREOF MAY BE REPRODUCED AND USED WITHOUT THE PRIOR WRITTEN CONSENT OF THE OWNER				