

REV.	ECN NO.	MODIFIED MARK	APPROVED
A	—	FIRST RELEASE	

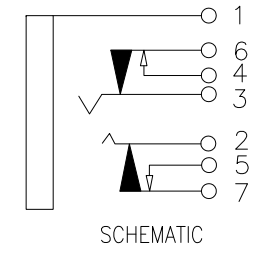

NOTES:
 ELECTRICAL:
 1:RATED CURRENT: 1A Max.
 2:RATED VOLTAGE: 30V AC.
 3:CONTACT RESISTANCE: 100 MILLIOHMS Max.
 AFTER TESTING:100 MILLIOHMS Max.
 4:INSULATION RESISTANCE: 100 MEGAOHMS Min.
 5:DIELECTRIC WITHSTANDING VOLTAGE: 500 VAC Min.
 MECHANICAL:
 1:INSERTION FORCE: 3N-25N.
 2:WITHDRAWAL FORCE: 3N-25N.
 3:DURRABILITY: 5000 CYCLES.
 ENVIRONMENTAL:
 TEMPERATURE RANGE: -20°C TO 60°C.

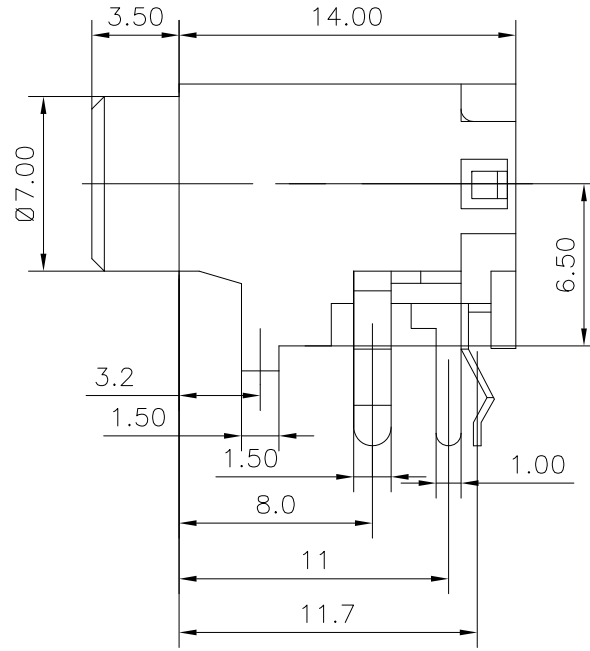
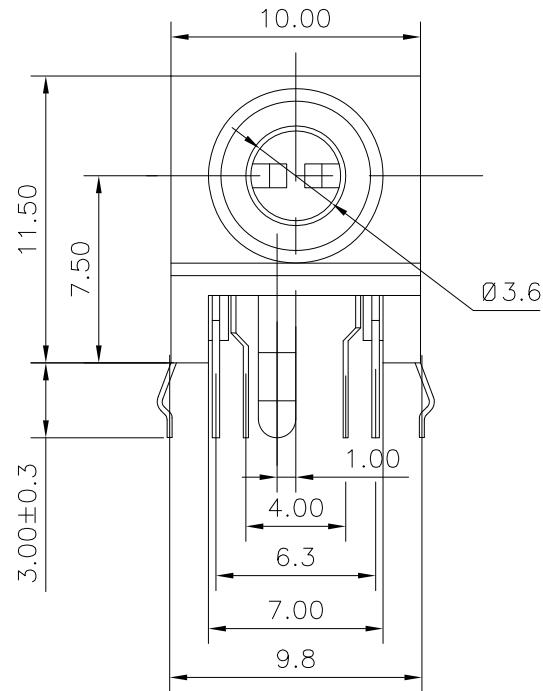
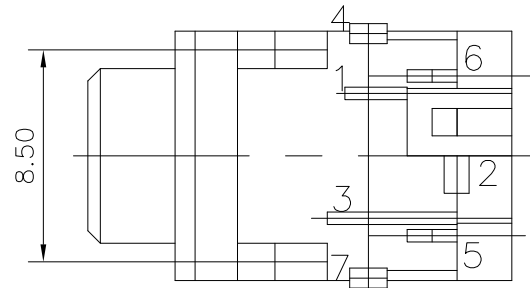
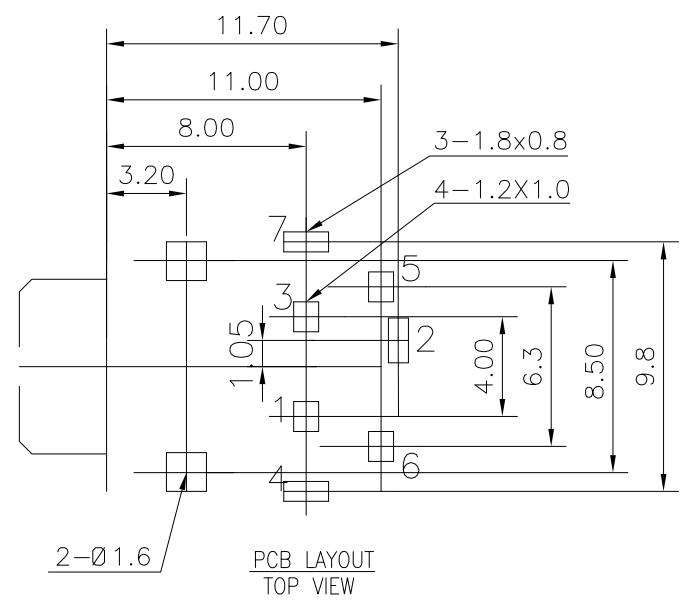

ANGLE	±5°
63 < L	±0.5
16 < L ≤ 63	±0.4
4 < L ≤ 16	±0.3
L ≤ 4	±0.2
TOL TABLE:	
THIS DOCUMENT IS THE PROPERTY OF TRENPRO TECHNOLOGY CO. LTD.,NO PART THEREOF MAY BE REPRODUCED AND USED WITHOUT THE PRIOR WRITTEN CONSENT OF THE OWNER	

MODEL NAME: SJ3509 (PART NO.)	
MAT'L: See table	DESIGN: X.H.Wang 11/05'18
FINISH: See table	CHECKED: L.W.Wu 11/05'18
Q'TY:/	APPROVED: X.Q.Hu 11/05'18

 广东正宝科技有限公司 GUANGDONG TRENPRO TECHNOLOGY CO. LTD.	
TITLE: 3.5 PHONE JACK	
DWG NO.:	REV.: A
UNIT: mm	VIEW: 
SCALE: 5:1	SHEET: 1/1
SIZE: A3	