

REV.	ECN NO.	MODIFIED MARK	APPROVED
A	—	FIRST RELEASE	

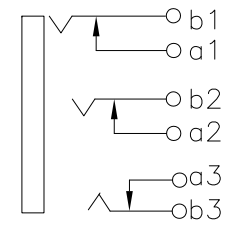

SCHEMATIC

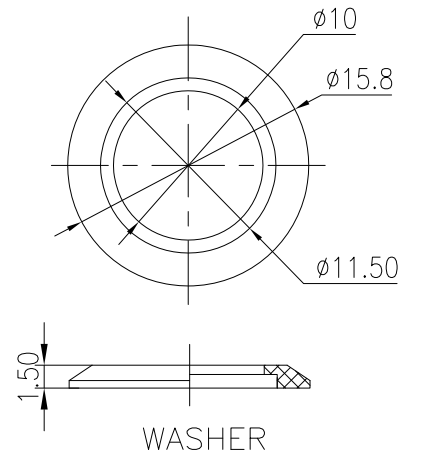
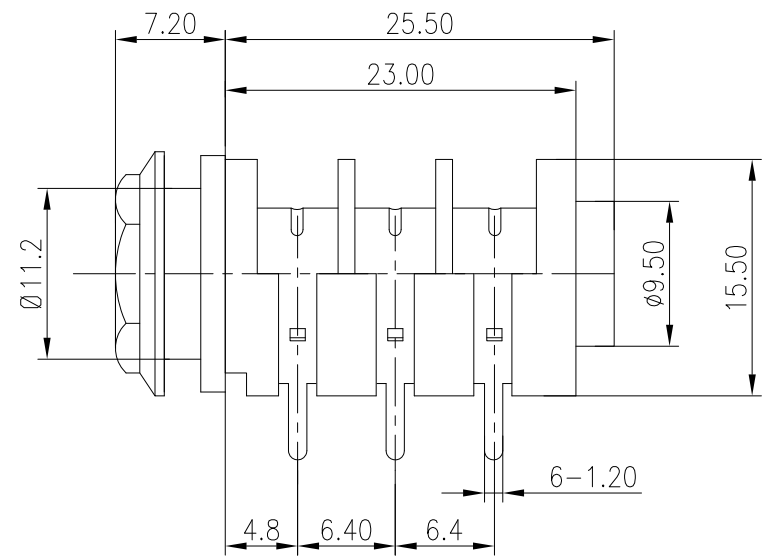
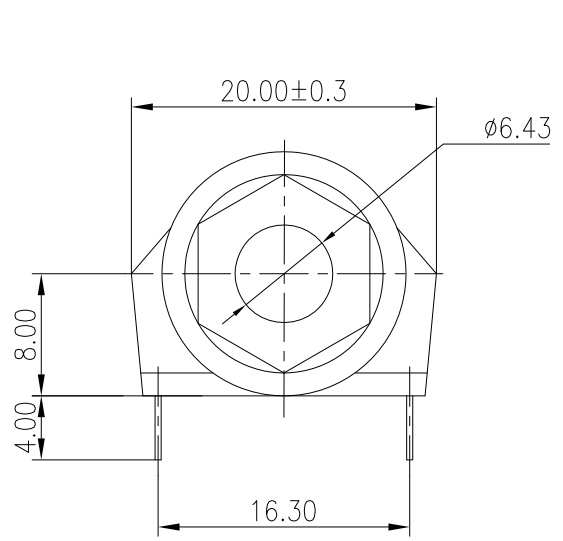
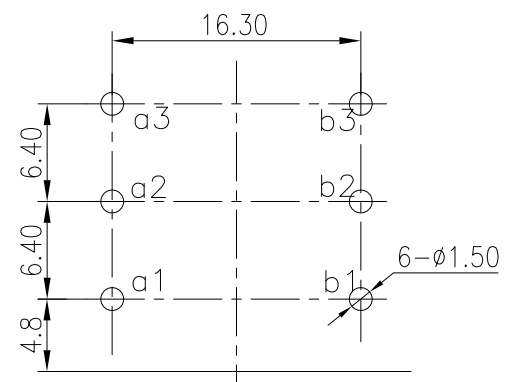

PCB LAYOUT  
TOP VIEW

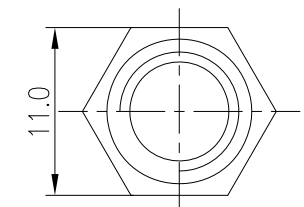
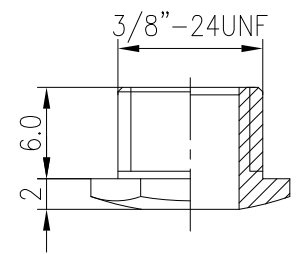

NUT

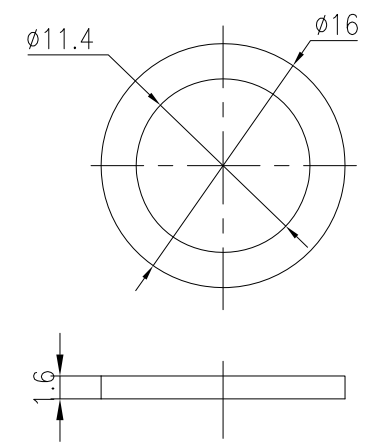

WASHER-A

NOTES:  
ELECTRICAL:  
1:RATED CURRENT: 1A Max.  
2:RATED VOLTAGE: 50V AC.  
3:CONTACT RESISTANCE: 100 MILLIOHMS Max.  
AFTER TESTING:100 MILLIOHMS Max.  
4:INSULATION RESISTANCE: 100 MEGAOHMS Min.  
5:DIELECTRIC WITHSTANDING VOLTAGE: 500 VAC Min.  
MECHANICAL:  
1:INSERTION FORCE: 5N-40N.  
2:WITHDRAWAL FORCE: 5N-40N.  
3:DURRABILITY: 5000 CYCLES.  
ENVIRONMENTAL:  
TEMPERATURE RANGE: -20°C TO 60°C.

ANGLE	±5°
63 < L	±0.5
16 < L ≤ 63	±0.4
4 < L ≤ 16	±0.3
L ≤ 4	±0.2
TOL TABLE:	
THIS DOCUMENT IS THE PROPERTY OF TRENPRO TECHNOLOGY CO. LTD.,NO PART THEREOF MAY BE REPRODUCED AND USED WITHOUT THE PRIOR WRITTEN CONSENT OF THE OWNER	

MODEL NAME: SJ6341A-6P (PART NO.)	
MAT'L: See table	DESIGN: X.H.Wang 09/20'18
FINISH: See table	CHECKED: L.W.Wu 09/20'18
Q'TY: /	APPROVED: X.Q.Hu 09/20'18

 广东正宝科技有限公司 GUANGDONG TRENPRO TECHNOLOGY CO. LTD.	
TITLE: 6.35 PHONE JACK	
DWG NO.:	REV.: A
UNIT: mm	VIEW: 
SCALE: 5:1	SHEET: 1/1
SIZE: A3	