

REV.	ECN NO.	MODIFIED MARK	APPROVED
A		FIRST RELEASE	

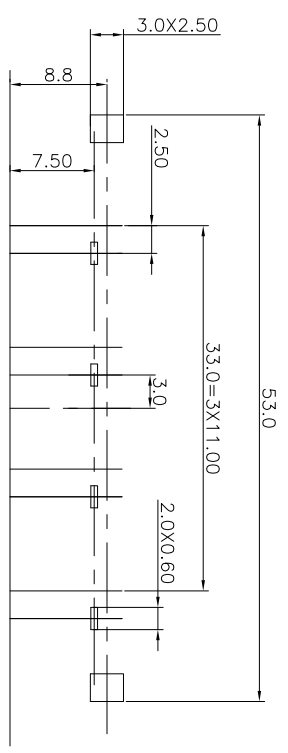
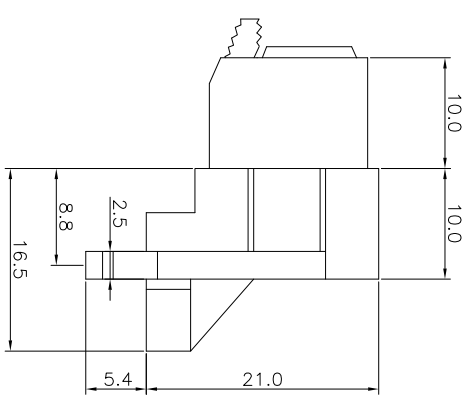
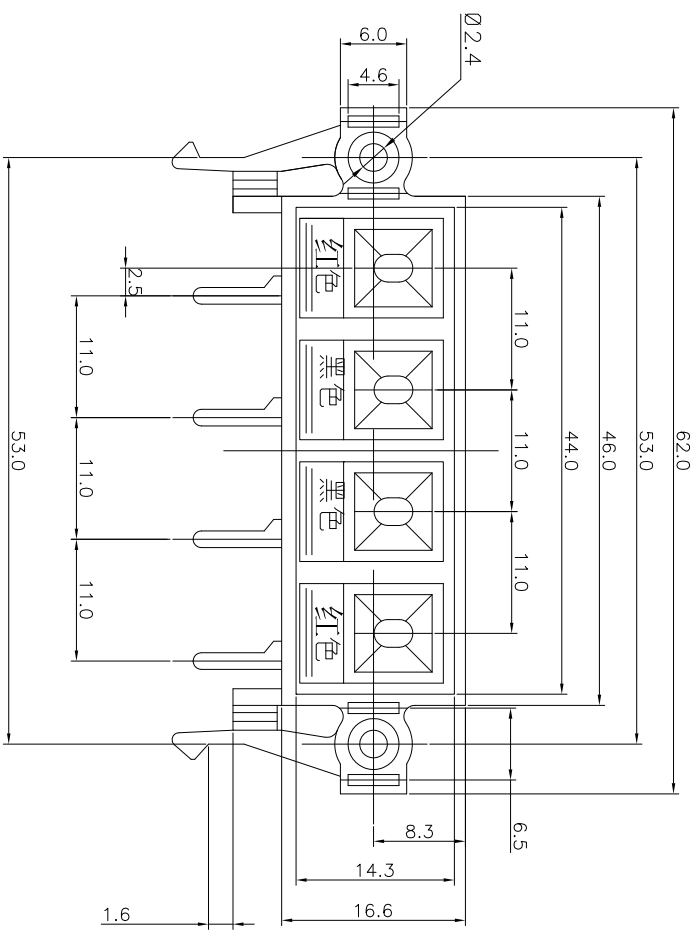

- NOTES:
- ELECTRICAL:
- 1: RATED CURRENT: 3A Max.
  - 2: RATED VOLTAGE: 50V AC.
  - 3: INSULATION RESISTANCE: 100 MEGAOHMS Min.
  - 4: DIELECTRIC WITHSTANDING VOLTAGE: 1200 VAC Min.
- MECHANICAL:
- 1: WIRE IN HOLD FORCE 5N (20#WIRE) MIN
  - 2: INSPECTED VOLTAGE, AT THE SPEED OF 6-10S PER MINUTES, THE SAMPLES ARE INSPECTED 10000 CYCLES, BUT THERE ARE NO DAMAGE ON THE PRESSURE AND THE RISING TEMPERATURE, ETC.
  - 3: APPLY 2kgf FORCE AT ANY DIRECTION, THERE NO LOOSE & NO CRACK

ANGLE	±5°	MODEL NAME: WP4-1B (PART NO.)	TITLE: WP PUSH TERMINAL
63 < L	±0.5	DESIGN: X.H.Wang 11/06'18	DWG NO.:
16 < L ≤ 63	±0.4	CHECKED: L.W.Wu 11/06'18	UNIT: mm
4 < L ≤ 16	±0.3	APPROVED: X.Q.Hu 11/06'18	VIEW:
L ≤ 4	±0.2	QTY: /	SCALE: 5:1

TOL TABLE:

THIS DOCUMENT IS THE PROPERTY OF TERPRO TECHNOLOGY CO., LTD. NO PART THEREOF MAY BE REPRODUCED AND USED WITHOUT THE PRIOR WRITTEN CONSENT OF THE OWNER

广东正宝科技有限公司  
GUANGDONG TERPRO TECHNOLOGY CO., LTD.

REV.: A

SHEET: 1/1

SIZE: A3