

REV.	ECN NO.	MODIFIED MARK	APPROVED
A		FIRST RELEASE	

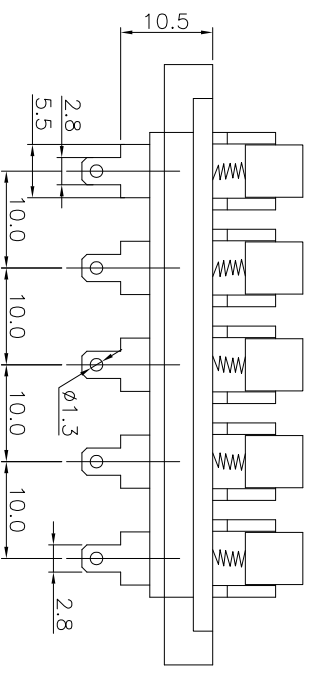
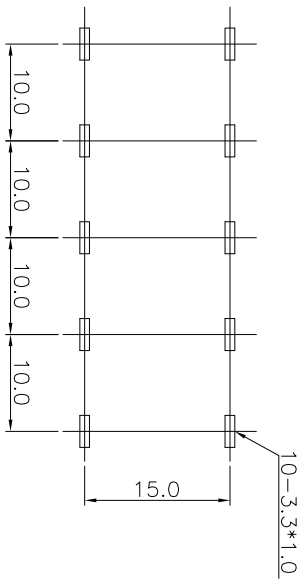
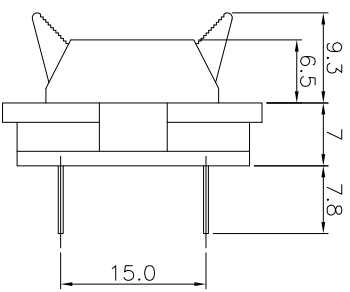
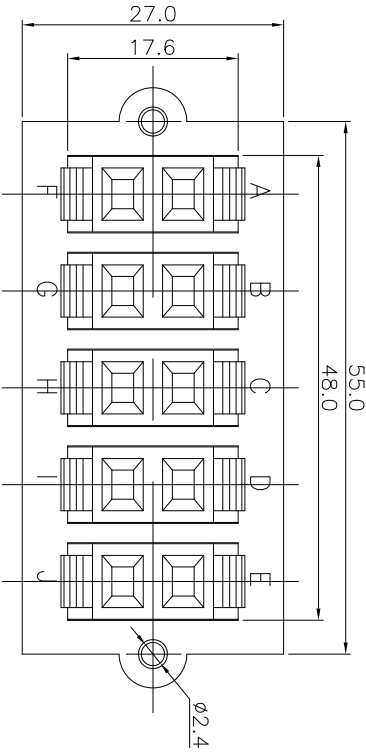

NOTES:
 ELECTRICAL:
 1:RATED CURRENT: 3A Max.
 2:RATED VOLTAGE: 50V AC.
 3:INSULATION RESISTANCE: 100 MEGAOHMS Min.
 4:DILECTRIC WITHSTANDING VOLTAGE: 1200 VAC Min.

MECHANICAL:
 1:WIRE IN HOLD FORCE 5N (20#WIRE) MIN
 2:INSPECTED VOLTAGE, AT THE SPEED OF 6-10S PER MINUTES, THE SAMPLES ARE INSPECTED 10000 CYCLES, BUT THERE ARE NO DAMAGE ON THE PRESSURE AND THE RISING TEMPERATURE, ETC.3:APPLY 2kgf FORCE AT ANY DIRECTION , THERE NO LOOSE & NO CRACK

ANGLE	±5°	MODEL NAME: WP10-12	 广东正宝科技有限公司 GUANGDONG ZHENGBAO TECHNOLOGY CO., LTD.
63 < L	±0.5	(PART NO.)	
16 < L ≤ 63	±0.4		
4 < L ≤ 16	±0.3		
L ≤ 4	±0.2		

TOL TABLE:		MAT'L:	DESIGN: X.H.Wang	TITLE: WP PUSH TERMINAL
THIS DOCUMENT IS THE PROPERTY OF ZHENGBAO ELECTRONICS CO.,LTD. ANY REPRODUCTION OR USE WITHOUT THE PRIOR WRITTEN CONSENT OF THE OWNER		FINISH:	CHECKED: L.W.Wu	DWG NO.:
Q'TY: /	APPROVED: X.Q.Hu	DATE: 08/16/18	UNIT: mm	VIEW:
	SCALE: 5:1	SHEET: 1/1	SIZE: A3	REV.: A