

REV. A	ECN NO.	MODIFIED MARK	APPROVED
		FIRST RELEASE	

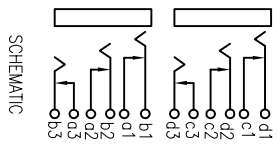
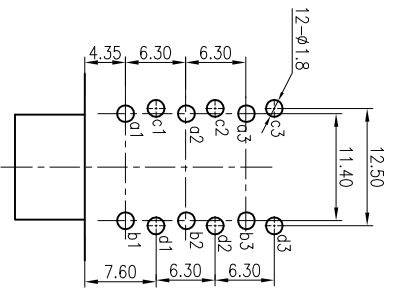
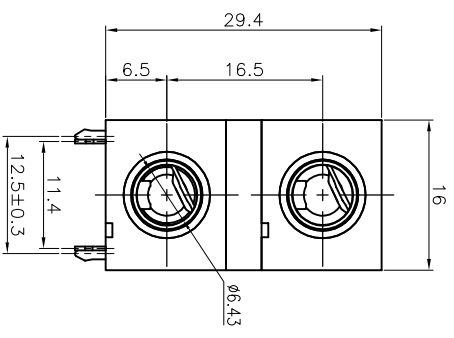
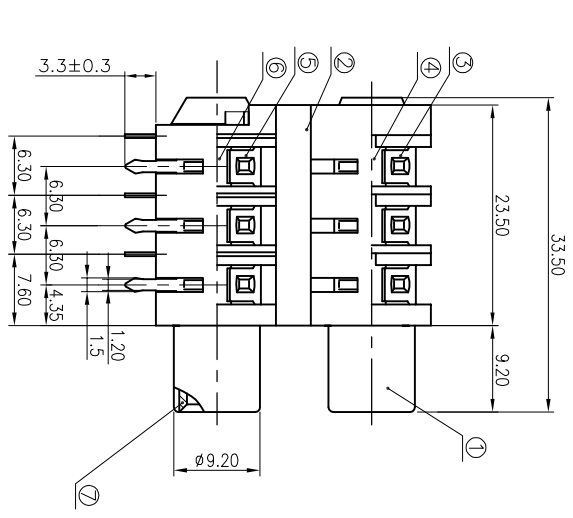

NOTES:
 ELECTRICAL:
 1: RATED CURRENT: 3A Max.
 2: RATED VOLTAGE: 50V DC.
 3: CONTACT RESISTANCE: 100 MILLIOHMS Max.
 AFTER TESTING: 100 MILLIOHMS Max.
 4: INSULATION RESISTANCE: 100 MEGAOHMS Min.
 5: DIELECTRIC WITHSTANDING VOLTAGE: 500 VAC Min.
 MECHANICAL:
 1: INSERTION FORCE: 5N-40N.
 2: WITHDRAWAL FORCE: 5N-40N.
 3: DURABILITY: 5000 CYCLES.
 ENVIRONMENTAL:
 TEMPERATURE RANGE: -20°C TO 60°C.

⑦	SOCKET	2	BRASS	Ni PLATED	
⑥	TERMINAL-D	3	BRASS t=0.4	Ag PLATED	ROHS
⑤	TERMINAL-C	3	BRONZE t=0.4	Ag PLATED	
④	TERMINAL-B	3	BRASS t=0.4	Ag PLATED	
③	TERMINAL-A	3	BRONZE t=0.4	Ag PLATED	
②	COVER	1	PA66	BLACK	
①	HOUSE	2	PA66	BLACK	
NO.	PART NAME	Q'TY	MATERIAL	FINISH/COLOR	REMARK
ANGLE	±5°				
63 < L	±0.5				
16 < L ≤ 63	±0.4				
4 < L ≤ 16	±0.3				
L ≤ 4	±0.2				

MODEL NAME: SJ6357KA-1P
 (PART NO.)



广东正宝科技有限公司
 GUANGDONG TREPHNO TECHNOLOGY CO., LTD.

DESIGN: X.H.Wang 03/09/21 TITLE: 6.35 PHONE JACK

CHECKED: L.W.Wu 03/09/21 DWG NO.:

APPROVED: X.Q.Hu 03/09/21 UNIT: mm VIEW: SCALE: SHEET: 1/1 SIZE: A3

TOL TABLE:
 THIS DOCUMENT IS THE PROPERTY OF TREPHNO TECHNOLOGY CO., LTD. NO PART THEREOF MAY BE REPRODUCED AND USED WITHOUT THE PRIOR WRITTEN CONSENT OF THE OWNER