

| | | | |
|------|---------|---------------|----------|
| REV. | ECN NO. | MODIFIED MARK | APPROVED |
| A | | FIRST RELEASE | |

NOTES:

- ELECTRICAL:
 1:RATED CURRENT: 3A Max.
 2:RATED VOLTAGE: 50V AC.
 3:INSULATION RESISTANCE: 100 MEGAOHMS Min.
 4:DILECTRIC WITHSTANDING VOLTAGE: 1200 VAC Min.
- MECHANICAL:
 1:WIRE IN HOLD FORCE 5N (20#WIRE) MIN
 2:INSPECTED VOLTAGE, AT THE SPEED OF 6-10S PER MINUTES, THE SAMPLES ARE INSPECTED 10000 CYCLES, BUT THERE ARE NO DAMAGE ON THE PRESSURE AND THE RISING TEMPERATURE, ETC.3.APPLY 2kgf FORCE AT ANY DIRECTION , THERE NO LOOSE & NO CRACK

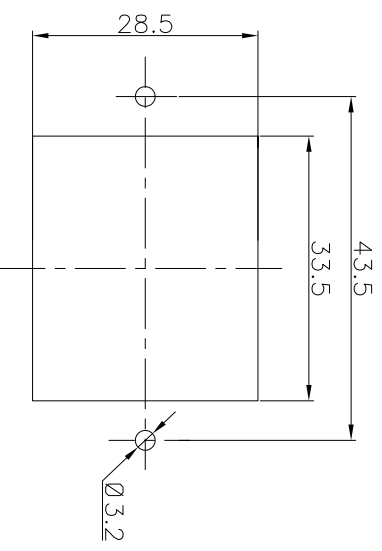
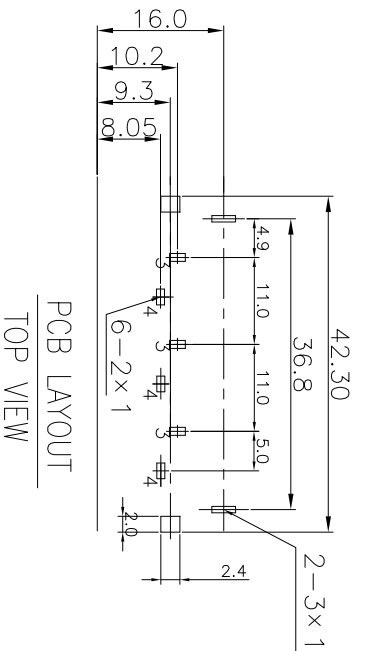
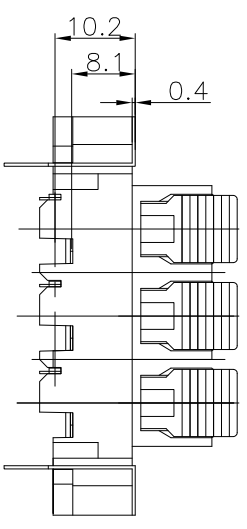
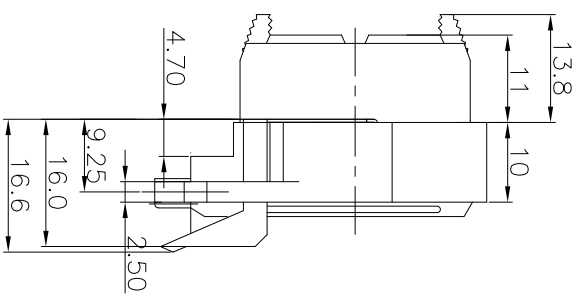
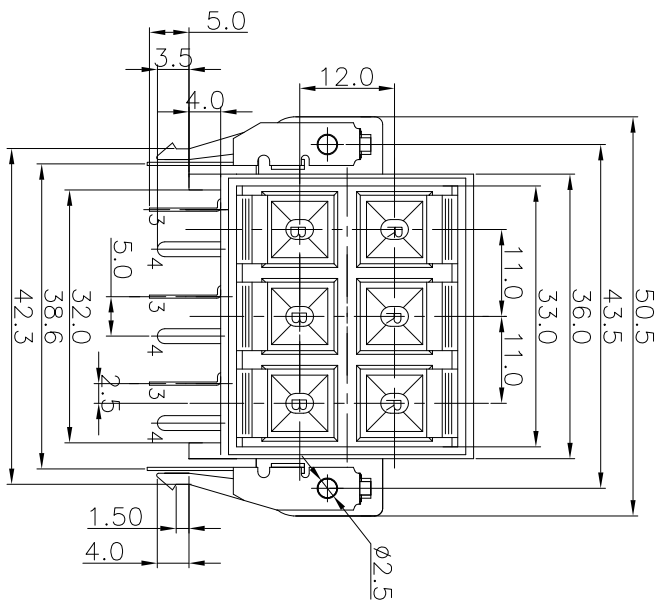

PCB LAYOUT
TOP VIEW

PANEL CUT OUT

| | |
|-------------|------|
| ANGLE | ±5° |
| 63 < L | ±0.5 |
| 16 < L ≤ 63 | ±0.4 |
| 4 < L ≤ 16 | ±0.3 |
| L ≤ 4 | ±0.2 |

TOL TABLE:
 THIS DOCUMENT IS THE PROPERTY OF
 TRENPRO TECHNOLOGY CO.,LTD,NO PART
 THEREOF MAY BE REPRODUCED AND
 USED WITHOUT THE PRIOR WRITTEN
 CONSENT OF THE OWNER

| | | |
|------------------------------------|---------------------------|-------------------------|
| MODEL NAME: WP6-2B/E (PART NO.) | DESIGN: X.H.Wang 11/06'18 | TITLE: WP PUSH TERMINAL |
| MAT'L: See table | CHECKED: L.W.Wu 11/06'18 | DWG NO.: |
| FINISH: See table | APPROVED: X.Q.Hu 11/06'18 | UNIT: mm |
| Q'TY: / | VIEW: 5:1 | SCALE: SHEET: 1/1 |
| | REV.: A | SIZE: A3 |



广东正宝科技有限公司
 GUANGDONG TRENPRO TECHNOLOGY CO.,LTD.